

THREAD
DIAMETER: _____
PITCH: _____
RH or LH: _____

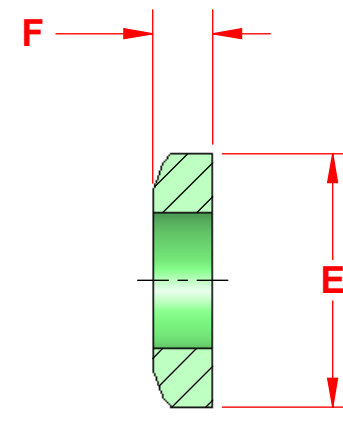

SECTION VIEW OF SEAT

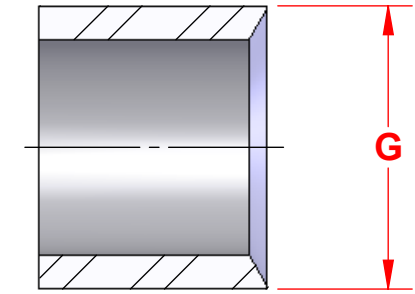

SECTION VIEW OF RING

Please complete the following and e-mail or fax this form to Concor Tool & Machine.
 E-mail: sales@concordtool.com Fax: 1-715-462-3205

MACHINE MAKE:		
MACHINE MODEL		
TIP O.A.L:	A	
NOSE ANGLE:	B	
HEAD DIAMETER:	C	
PILOT DIAMETER:	D	
THREAD:		
SEAT DIAMETER:	E	
SEAT WIDTH:	F	
RING DIAMETER:	G	
BACK OF SEAT TO START OF NOSE ANGLE	H	
THREAD LENGTH:	J	
NOSE RADIUS	R	
NAME:		
COMPANY:		
ADDRESS:		
TELEPHONE:		
FAX:		
P.O. NUMBER		

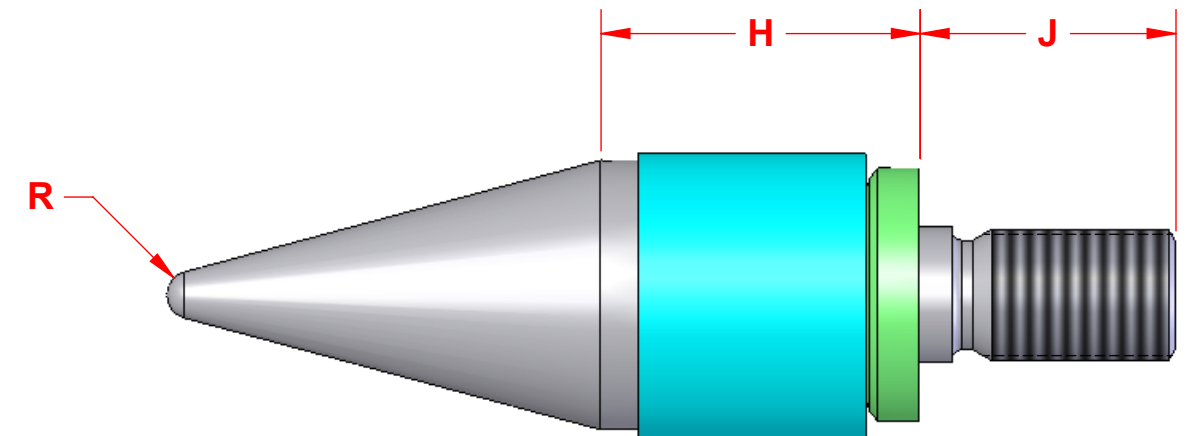

SPECIAL INFORMATION, (STYLE, MATERIALS, OPTIONS, ETC.)

